

ALLMÄNNA ANVISNINGAR:

KOORDINATSYSTEM SWEREF
HÖJDSYSTEM RH2000

DENNA RITNING LÄSES IHOP MED PLANRITNINGAR.
MÅTT ANGES I METER (m).
PLUSHÖJDER ANGES I METER (m).

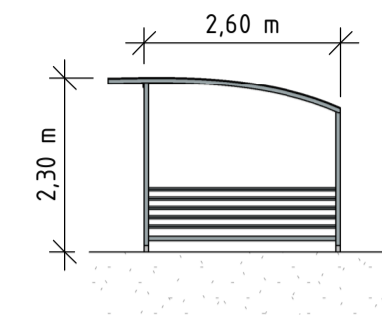

CYKELGARAGE GAVEL 1

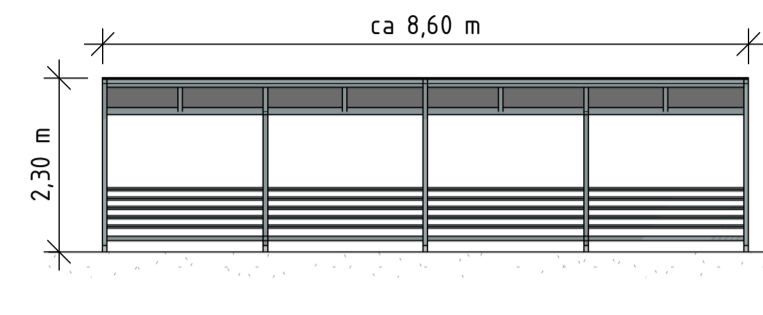

CYKELGARAGE FRAMSIDA

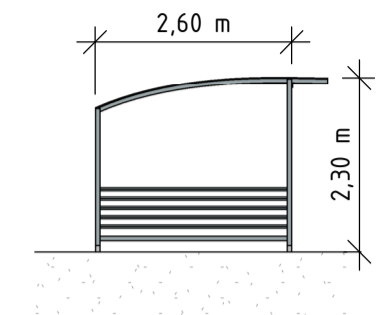

CYKELGARAGE GAVEL 2

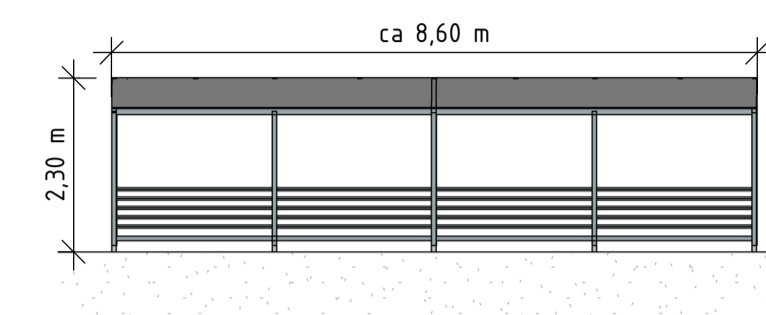

CYKELGARAGE BAKSIDA

CYKELGARAGE CAPELLA, STÅLRAM MED PLASTTAK - UTEPRODUKTER INKL. FÖRLÄNGNING CYKELGARAGE CAPELLA, PLASTTAK
ANTAL: 2 ST, SE ÄVEN MARKHANDLING

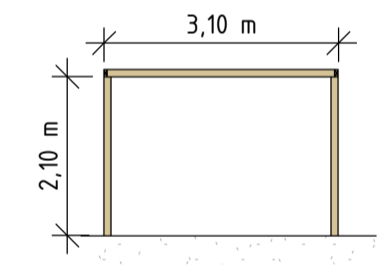

PERGOLA GAVEL 1

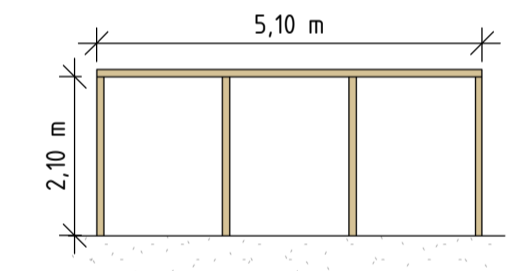

PERGOLA LÅNGSIDA 1

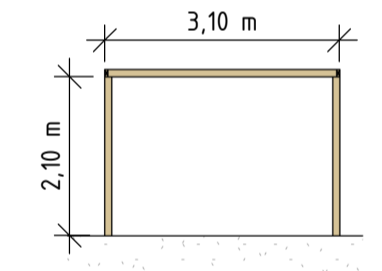

PERGOLA GAVEL 2

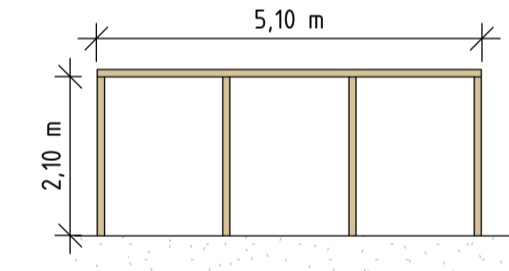

PERGOLA LÅNGSIDA 2

PERGOLA UTFÖRS HELT I TRYCKT VIRKE
ANTAL: 1 ST, SE ÄVEN MARKHANDLING

A	PM02-A	2025-01-14	RF
BET	ÄNDRINGEN AVSER	DATUM	SIGN

BYGGLOVSHANDLING



<input checked="" type="checkbox"/>	A	MINJAR AB	0739-10 01 05
	K	MINJAR AB	0739-10 50 66
	VS	COMFORT-KEDJAN AB	019-777 02 00
	V	VENTEX ENTREPRENAD AB	0456-135 95
	E	ETG EL-TELEGRUPPEN AB	0454-30 64 97
	L	LANDSKAPSARK.	XXXXXXXXXX
	G	TYRÉNS AB	XXXXXXXXXX

UPPDRAGS NR	REDA/KONSTR. AV	HANDLÄGGARE
9305034	RF	Ö.NILSSON
DATUM	ANSVARIG	
2025-01-14	ÖRJAN NILSSON	

TORSVIK 1, HÄRNÖSAND
NYBYGGNAD AV FLERBOSTADSHUS
CYKELGARAGE & PERGOLA
FASADER

SKALA A1	SKALA A3	NUMMER	BET
1:100	1:200	A-40-3-201	A

2025-01-14 14:37:39

HANDLINGEN ÄR I SIN HELHET SKYDDAD UPPHOVSRÄTTSLIGT

